

4.1 Controller Board

Figure 25 shows the general layout of the Lobby Control Unit main controller board. See Figure 27 and Figure 31 for a detailed description of the connectors at the bottom and top of the controller board.

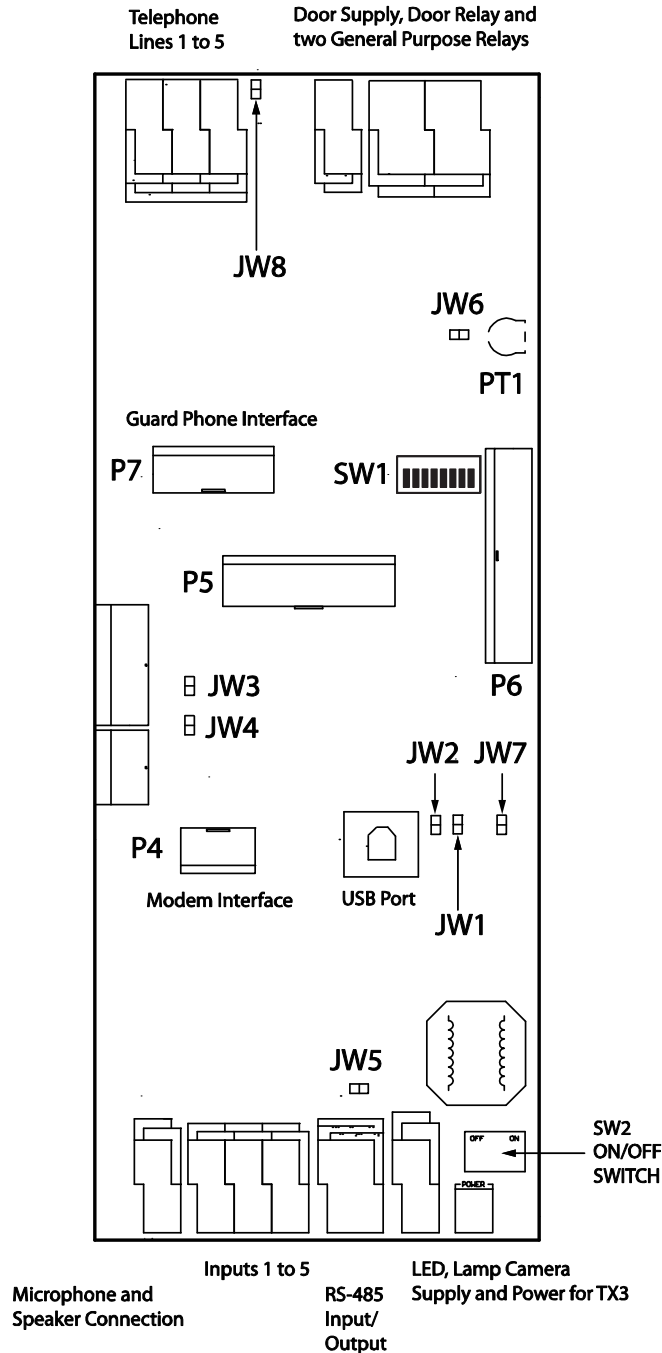

Figure 25. Lobby Control Unit Main Controller Board

4.1.1 Connectors

USB. Computer connection for firmware download and configuration.

P4. Modem Module connector.

P5. IP Module connector.

P6. Key pad and front door LCD display.

P7. Guard Phone Board connector.

4.1.2 Potentiometer

PT1 (if present). Pulse phone potentiometer. This potentiometer is normally factory set and does not require adjustment.

4.1.3 Switches

SW1. SW1 sets the unit's RS-485 ID (node address) and the IP addressing mode.

SW2. SW2 turns the unit's power ON and OFF for servicing, or to re-start the unit.

4.1.4 Jumpers

JW1. JW1 is used for updating firmware and is normally open.

JW2. JW2 is used for updating firmware and is normally open.

JW3. JW3 is not used and is left open.

JW4. JW4 is not used and is left open.

JW5. JW5 is not used and is left open.

JW6. JW6 is left closed.

JW7. JW7 is on for a Touch Screen unit, and off otherwise.

JW8. JW8 defines the operating state of the door strike relay as normally open or normally closed. A jumper wire connects to either the normally open (position 2 - top) or normally closed pin (position 1 - bottom).

JW11:

- If the panel has the MC-009 microphone, close JW11.

- If the panel has the MC-012 microphone, open JW11.



MC-009 microphone
JW11 on or closed



MC-012 microphone
JW11 off or open

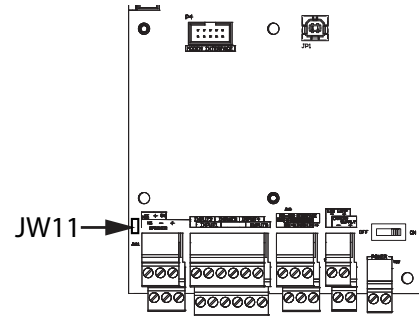

Figure 26 Microphones and JW11

4.2 Controller Board Connectors - Bottom

Figure 27 shows the connectors at the bottom of the controller board.

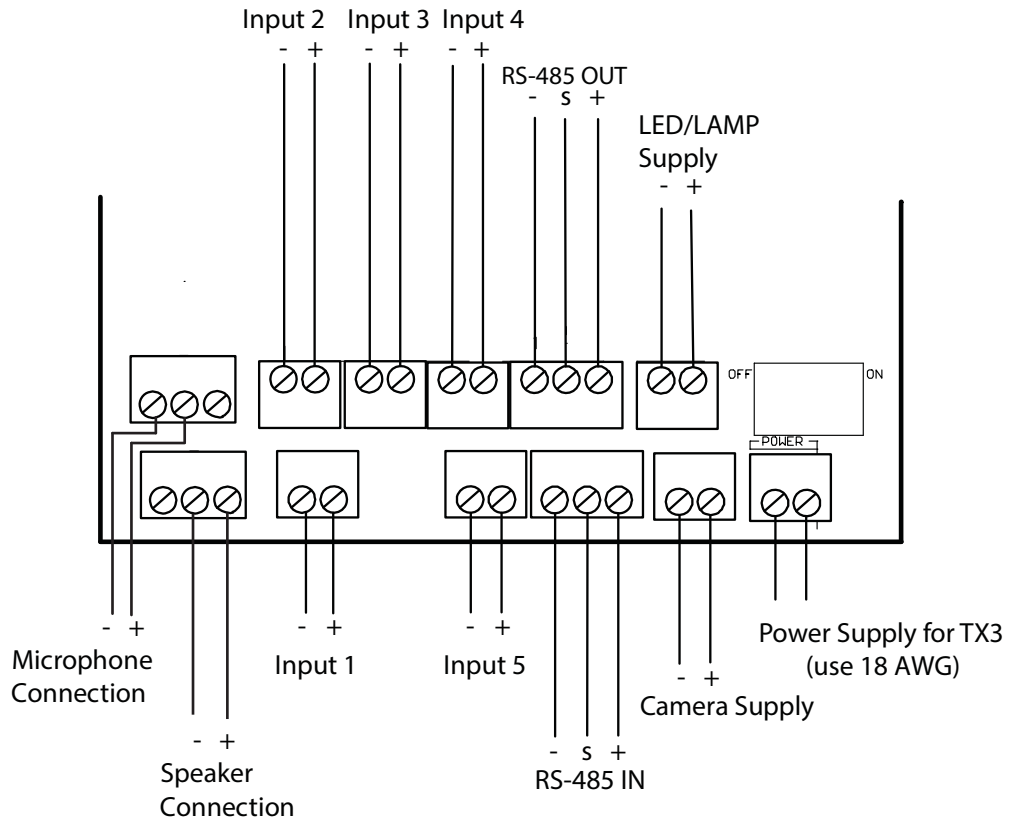

Figure 27. Controller Board Connectors - Bottom

4.2.1 Microphone Connection

The microphone connection is situated at the bottom left of the main controller board. It connects to the front display and is factory set.

4.2.2 Speaker Connection

The speaker connection is situated at the bottom left of the main controller board. It connects to the front display and is factory set.

4.2.3 Inputs 1 to 5

Inputs 1 to 5 are situated at the bottom of the main controller board and are assigned specific functions. Inputs 1 to 3 have pre-defined functions and connect to specific devices. Inputs 4 and 5 are general purpose inputs that can be correlated to activate a general purpose output.

Inputs 1 to 5 are designated as follows (see Figure 27):

Input 1. Postal Lock. Input 1 connects to the Postal Lock. Activation of this input unlocks the main door and starts the main door timer. The door locks when the timer expires or when the door sense input is activated. Daily usage is set as unlimited or limited. When set as limited daily usage is set according to a pre-defined number. Any attempt to use the postal lock beyond a set daily limit causes a warning message to appear and the system to return to normal operation. Input 1 also, when configured, activates a general purpose output to perform any required function.

Input 2. Fire Panel. Input 2 connects to the fire alarm panel and receives fire notification. Activation of this input unlocks the main and auxiliary doors. These outputs are active as long as the fire panel input is active. Input 2 also, when configured, activates a general purpose output to perform any required function.

Input 3. Main Door Sense. Input 3 connects to the door sense switch. Unlocking the main door activates the main door open timer. Activation of the Main Door Sense locks the main door and resets the main door open timer. This function is typically used to prevent 'tailgating'. Input 3 also, when configured, activates a general purpose output to perform any required function.

Input 4. General Purpose. Input 4 is a general purpose input that, when configured, activates a general purpose output to perform any required function. An example of a typical application is the use of an optional tamper switch (see Figure 28).

Input 5. General Purpose. Input 5 is a general purpose input that, when configured, activates a general purpose output to perform any required function.

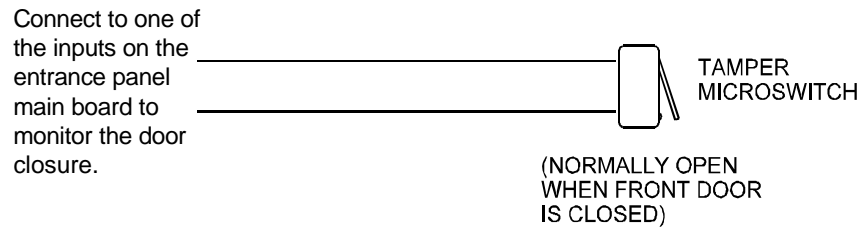

Figure 28. Tamper Switch

4.2.4 RS-485

22 AWG twisted pair, maximum length: 4000 ft (1219.2 m)

Mircom recommends shielded cable

An RS-485 terminal lets you easily connect multiple telephone, card access and elevator restriction controllers across a network. The RS-485 connection is situated at the bottom middle of the main controller board and consists of two separate terminals, each for an input and output. See Figure 29.

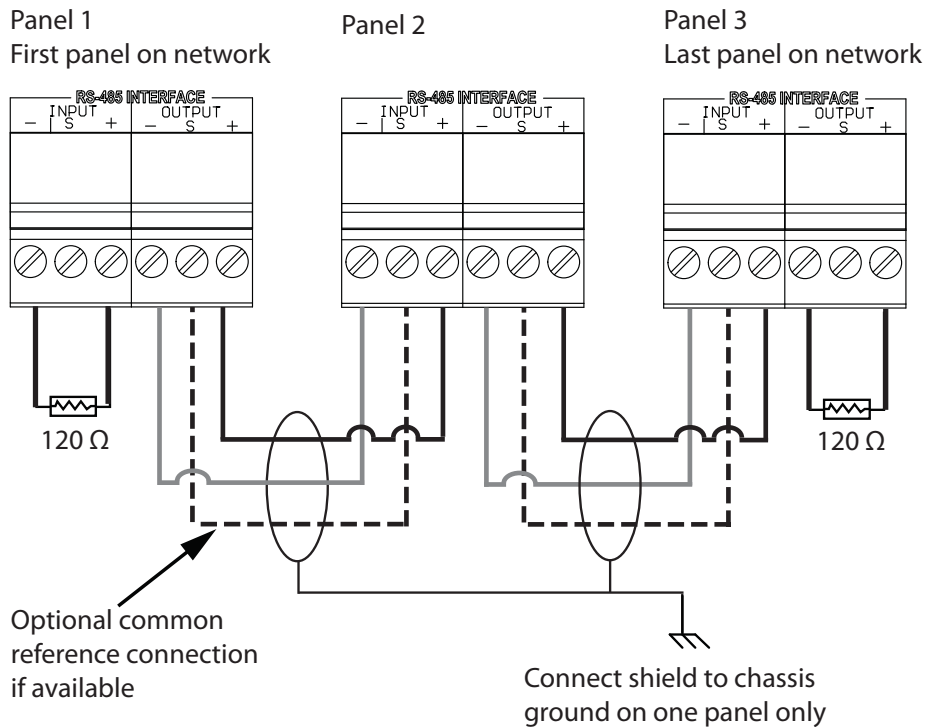

Figure 29. RS-485 Connections

4.2.5 Auxiliary Camera Supply

The camera supply connection is situated at the bottom right of the main controller board and provides + 12 Vdc, 600 mA. The camera is controlled by one of the general outputs. The camera's positive terminal connects to the normally open (NO) general output relay contact. The common (C) contact of the general output relay connects to the + 12 Vdc supply terminal. The camera is typically configured to operate when the main door is open.

4.2.6 LED/Lamp Supply

The LED/Lamp connection is situated at the bottom right of the main controller board. This lamp is used with the paper directory models to illuminate the paper directory.

4.2.7 Power Supply

The power supply connection is situated at the bottom right of the main controller board and receives 16 Vac, 40 VA. An external PS-4 or PS-4P plug-in transformer connects to the power terminals. Refer to Figure 27 and Figure 30.

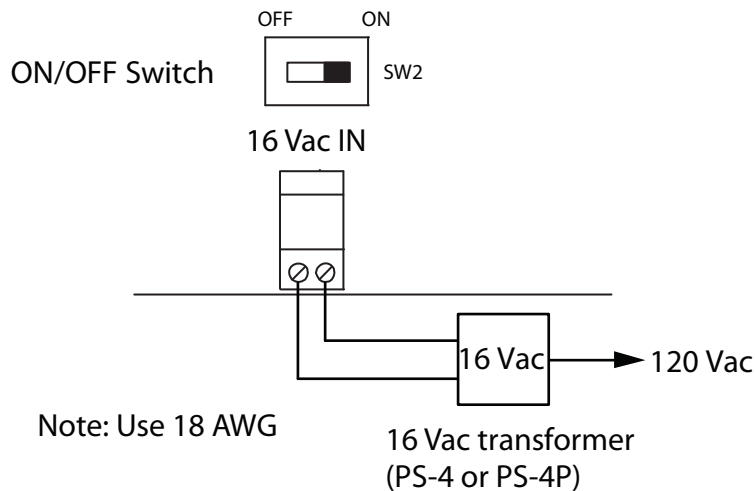

Figure 30. Power Supply

4.3 Controller Board Connectors - Top

Figure 31 shows the connectors at the top of the controller board.

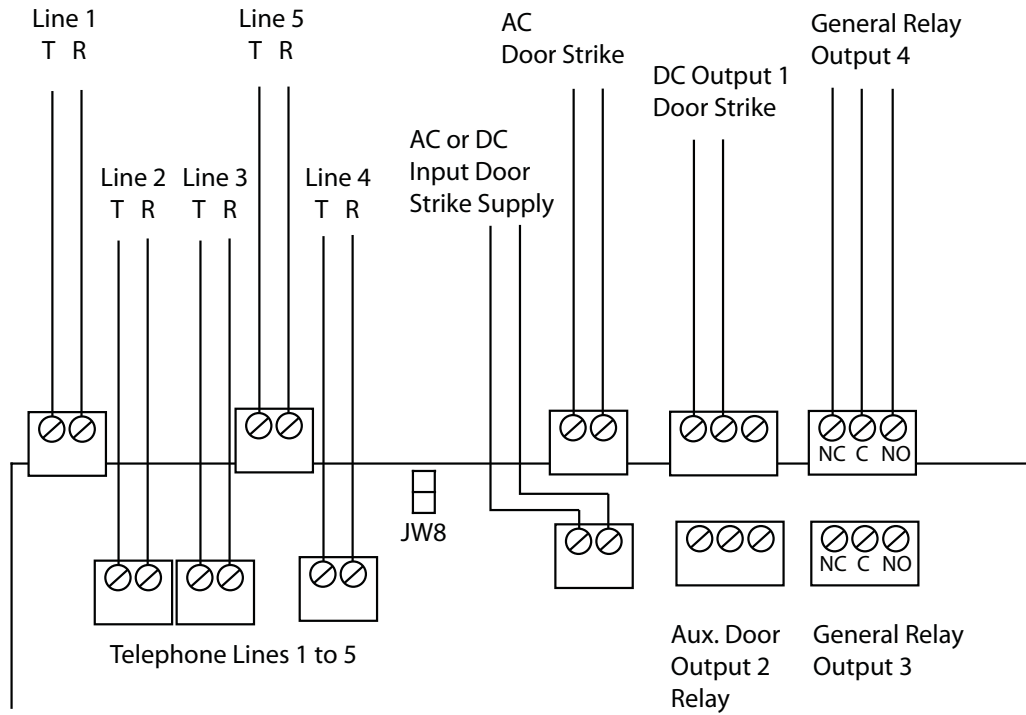

Figure 31. Controller Board Connectors - Top

4.3.1 Telephone Lines 1 to 5

The telephone lines are situated at the top left of the main controller board.

Both NSL and ADC lines can be connected. Each T/R line is polarity insensitive and can be reversed.

Note: Non-configurable PBX systems are not supported. For more information, contact technical support at Mircom.

4.3.2 JW8

JW8 must be set to define the operating state of the door strike relay as normally open or normally closed. Use the jumper wire to connect to either the normally open (position 2 - top) or the normally closed pin (position 1 - bottom). For example, when using a maglock, connect the jumper wire to the normally closed pin (position 1).

4.3.3 AC or DC Input Door Strike Supply

The power for the door strike is customer supplied and provides AC or DC power for one of the door strike outputs.

Note: The controller is able to convert an AC supply to a DC output. The reverse is not true. Consequently, an AC door strike will not work with a DC power supply.

The maximum supply for the AC or DC Input Door Strike must not exceed:

- 28 VAC / 1 A max
- 30 VDC / 1 A max

4.3.4 AC Output Door Strike

The AC Output Door Strike receives power from the AC Input Door Strike supply. The AC power output remains the same as the power supplied to the AC Input Door Strike.

The AC Output Door Strike is configured for activation by the resident's telephone keypad.

4.3.5 DC Output Door Strike

The DC Output Door Strike receives power from the AC or DC Input Door Strike supply and is configured for activation by the resident's telephone keypad. When using a DC input supply, the DC power output remains the same as the input.

When using a dry contact for the main door instead of a door strike or maglock, wire the external controller to the left hand terminals of the AC Door Supply and Input Door Supply as shown in Figure 32. JW8 controls whether the contact is normally open or normally closed.

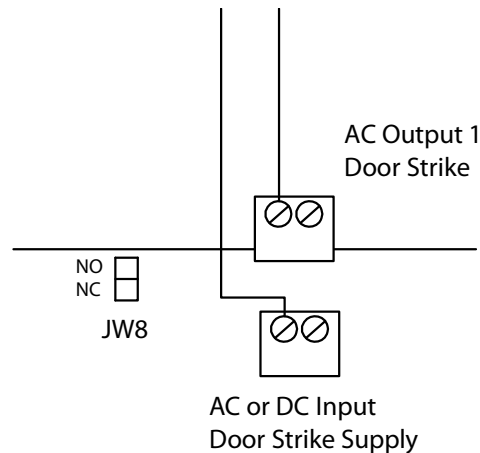

Figure 32. Main Door Dry Contact Wiring

4.3.6 Auxiliary Door Relay (Output 2)

The auxiliary door output is configured for activation by the resident's telephone keypad and can be configured to activate general outputs. This relay is a relay contact programmable output with these ratings:

- normally open (NO)
- normally closed (NC) available
- 125 VAC / 2 A
- 30 VDC / 1 A

4.3.7 General Output Relays 3 and 4

Outputs 3 and 4 are relay contact programmable outputs with the following characteristics.

- normally open (NO)
- normally closed (NC) available
- 125 VAC / 2 A
- 30 VDC / 1 A

The general output relays can be correlated to operate for the following events:

- when inputs 1 to 5 are active
- call is started